

Case Study

Brewing Company Stout On Electrical Safety

When brewery workers connect and disconnect mobile pump carts, they are in a wet environment with an increased risk of electrical shock. MELTRIC Switch-Rated plugs retrofitted on production equipment at Founders Brewery prevent this problem and improve brewery safety.

Opening a craft brewery may be the dream of a lifetime, as it was for Mike Stevens and Dave Engbers who started up Founders Brewery in Grand Rapids, MI, but the reality of operating a brewery takes an immense amount of planning, management, and hard work to make that dream come true. After some initial challenges, they succeeded at brewing a flavorful brand of complex ales, which has found broad market acceptance; its beer has consistently won medals at the World Beer Cup and the Great American Beer Festival. Founders has experienced steady growth since it opened for business and is now distributed across the country.

The company's growth required Founders to expand brewery operations and increase the size of the production staff. Despite an excellent safety record, Founders management became more interested in workplace safety as the staff grew and since much of the production work is accomplished in a wet environment. This interest led them to David Patchak of J.P. Motors & Drives Inc. who introduced Alec Mull, Founders' Director of Brewery Operations, to MELTRIC Switch-Rated safety plugs as a convenient and cost-effective means to improve brewery safety.

Electrical Safety at Founders Brewery

Breweries are industrial operations that possess the same potential for accidents as any other type of manufacturing facility. Some of the primary sources of accidents in breweries involve rotating machinery such as conveyors, pumps, and motors. Other potential areas of safety hazards include hot liquids, pressurized systems, confined spaces, caustic chemicals, and electrical shock.

According to OSHA accident reports, electrical shock accidents at breweries have occurred while technicians work on energized equipment such as power panels and motor controls. To combat the risk of electrical shock accidents, Founders Brewery installed MELTRIC Switch-Rated plugs and receptacles on its brewery production equipment such as mobile pump carts, keg washers, motors, and other portable equipment. "These safety plugs help prevent electrical safety accidents before they happen," said Alec Mull, Founders' Director Brewing Operations.

To put this into perspective, many breweries use pin-and-sleeve, twist-lock, or bladed-style electrical plugs to connect brewery equipment to electrical power. Not only are these types of plugs more expensive, they can pose electrical safety hazards for brewery workers



MELTRIC Switch-Rated plugs have a modular design and flexible mounting accessories allowing them to be used in a variety of configurations including, in-line, cord drop, or wall mounting. MELTRIC Switch-Rated connectors are UL/CSA rated for motor and branch circuit disconnect switching. They meet NEC line of sight motor disconnect switching requirements.



MELTRIC Switch-Rated plugs and receptacles are Type 4X, providing a watertight connection for washing down production equipment.

meltric.com

4765 W. Oakwood Park Drive • Franklin, WI 53132
414-433-2700 • Fax 414-433-2701

©2021 MELTRIC Corporation. All rights reserved. CS_FFOUNDERS_BREWERY_B

 **MELTRIC**
A COMPANY OF MARECHAL ELECTRIC

in a wet operating environment. Says Patchak, "We sell MELTRIC products to businesses that use portable equipment. One of the things we tell our customers is that if an outside contractor is on your site and attempts to disconnect an energized pin and sleeve plug, this can expose a worker to arc flash and could be an OSHA violation, which you would be liable for if an accident occurs. MELTRIC eliminates this problem because of the unique safety features built into its safety-designed Switch-Rated plugs."

Worker Safety and Switch-Rated Functionality in a Single Plug

MELTRIC Switch-Rated plugs and receptacles combine the safety and functionality of a disconnect switch with the convenience of a plug and receptacle. They are ideally suited for making and breaking electrical connections on portable equipment commonly found in breweries. This increased safety is accomplished through a clever design that causes load making and breaking to occur in an enclosed arc chamber shrouded by a safety shutter so users are isolated from live parts; the plug cannot be physically removed from its receptacle until the load is safely disconnected. "Brewery safety is a keyword at Founders. We are in a wet environment all day so we don't want to put our staff at risk. MELTRIC plugs were the most cost-effective and the safest product we were able to secure. Since we don't have an electrician on site all the time, MELTRIC plugs add to the convenience," said Mull.

To obtain the functionality of a disconnect switch within a plug, Switch-Rated plugs are built with spring-loaded, butt-style contacts similar to those used on contactors and switchgear. Using end-to-end contact mating instead of sliding contacts provides a solid connection, and the spring-loading produces optimal contact pressure, which ensures that the integrity of the electrical connection is consistently maintained over thousands of operations. For superior electrical performance, Switch-Rated plugs are fitted with durable silver-nickel contacts in lieu of softer brass contacts commonly used by competitors who manufacture pin and sleeve plugs; brass contacts generally have poor contact resistance, resulting in a tendency to arc, which causes pitting, oxidization, and an overall shorter lifespan. Conversely, silver-nickel contacts possess increased resistance to contact pitting, inhibit the destructive effects of corrosion, and typically have a very long life span of reliable use. In addition, Switch-Rated connectors are UL/CSA rated for motor and branch circuit disconnect switching and meet NEC/CSA requirements for a line of sight disconnect switch.

Making and breaking connections with MELTRIC plugs is a quick and easy operation since the work is done by the integral spring-loaded mechanism instead of the user's physical motion, which is typical of pin-and sleeve or twist-type plugs. In MELTRIC plugs, the circuit is opened by simply depressing the pawl, which releases the energy in the spring-loaded operating mechanism,



Founders Brewery uses MELTRIC Switch-Rated plugs and receptacles on brewery production equipment such as mobile pump carts, keg washers, motors and other portable equipment. Any qualified worker can connect or disconnect a plug. Making and breaking connections with Switch-Rated plugs is a Risk Category '0' operation, so the need for cumbersome PPE when working near live parts is eliminated.

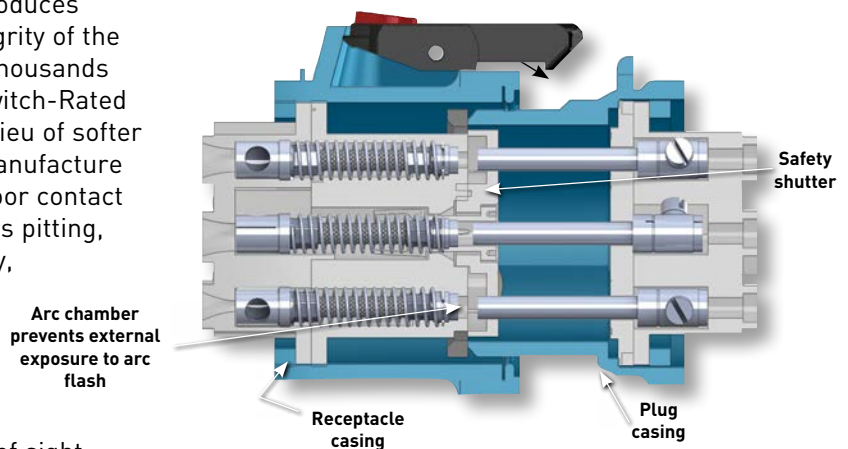

To obtain the functionality of a disconnect switch within a plug, MELTRIC Switch-Rated plugs are built with spring-loaded, butt-style contacts similar to those used on contactors and switchgear. This ensures that the integrity of the electrical connection is consistently maintained over thousands of operations.

instantaneously breaking the circuit, and ejecting the plug to the 'OFF' position. Contact breaking time is about 15 milliseconds. The quick break mechanism is automatically reloaded when the plug is re-inserted. "MELTRIC plugs are quick to disconnect. If we want to test a piece of equipment, we can quickly change them out with these plugs," says Mull.

Brewery Safety and Efficiency Are a Top Priority

"We use MELTRIC plugs because brewery safety and efficiency are top priorities for Founders. MELTRIC connectors make both worlds easier for our brewery," says Alec Mull, Director Brewing Operations. Used on brewery equipment throughout Founders Brewery, MELTRIC Switch-Rated plugs are part of the excellent safety record at the brewery. "We stand behind the MELTRIC product for quality and reliability. The bottom line is they are a nice, simple, and safe device," says Mull.



Alec Mull, Director of Brewery Operations at Founders Brewing is as passionate about the safety of his fellow employees as his beer. "Brewery safety is a keyword at Founders. We are in a wet environment all day, so we don't want to put our staff at risk."