

This drawing is the property of MELTRIC Corporation, Franklin (Milwaukee) Wisconsin, USA. Any unauthorized copying of this drawing by any means, ENG/RD/06 REV: 20 ISSUED DATE: 1/15/11 or disclosure of its contents to any person not authorized by MELTRIC Corporation or its agents to receive it, is strictly prohibited.

G | F | E | D | C | B | A

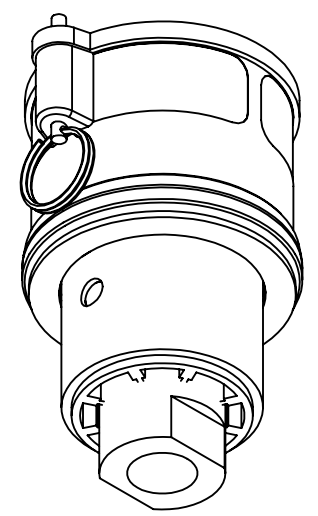
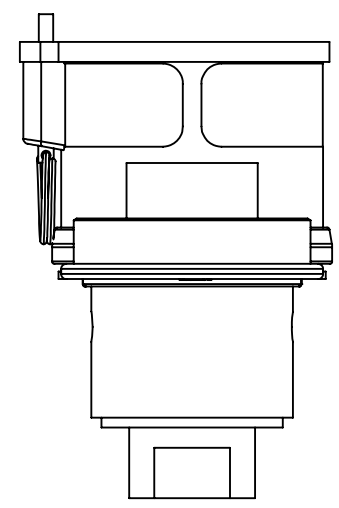
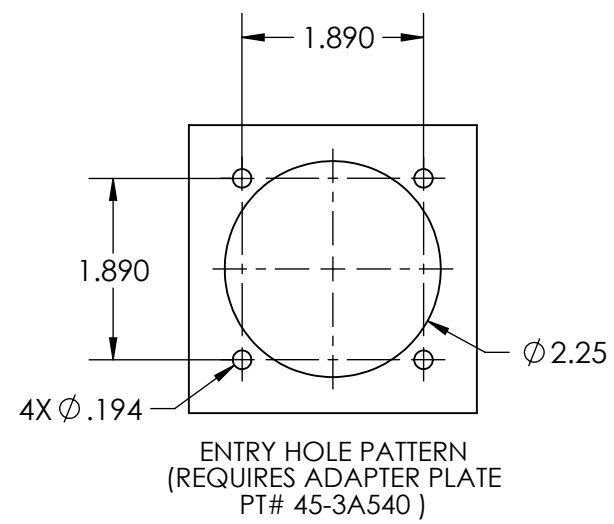
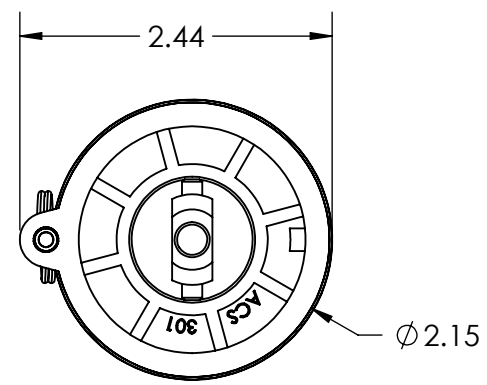
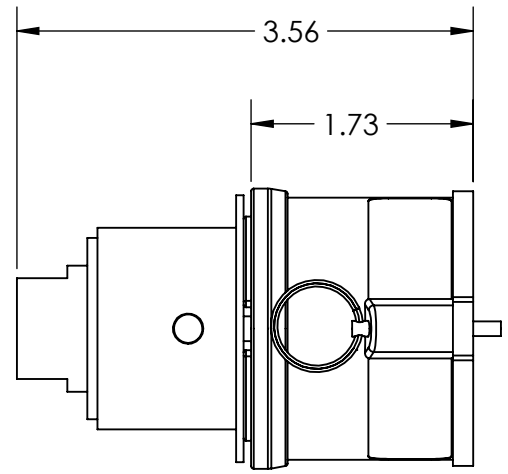

1
2
3
4
5
6

TOLERANCES UNLESS OTHERWISE SPECIFIED				
MACHINED SURFACES $\sqrt{125}$ MAX	ENGLISH 0.X ±0.05 0.XX ±0.01 0.XXX ±0.005			
GROUND SURFACES $\sqrt{32}$ MAX		DATE:	SCALE	MATERIAL:
ANGLE TOLERANCE ±1°		NTS	BLACK POLY CASING	
REMOVE BURRS & SHARP EDGES TO .015 MAX.		SHEET:	PART NUMBER	REVISION
DIMENSIONS SHOWN IN OVALS ARE INSPECTION DIMENSIONS.		1 OF 1	45-3800x-P80	A