

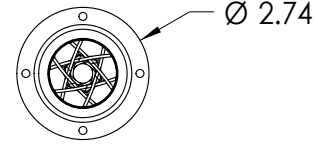

This drawing is the property of MELTRIC Corporation, Franklin (Milwaukee), Wisconsin, USA. Any unauthorized copying of this drawing by any means, or disclosure of its contents to any person not authorized by MELTRIC Corporation or its agents to receive it, is strictly prohibited.

G F E D C B A

PART NUMBER	CABLE RANGE
44-4A753-A	.750-.875"
44-4A753-B	.875-1.000"
44-4A753-C	1.000-1.125"
44-4A753-D	1.125-1.250"
44-4A753-E	1.250-1.375"

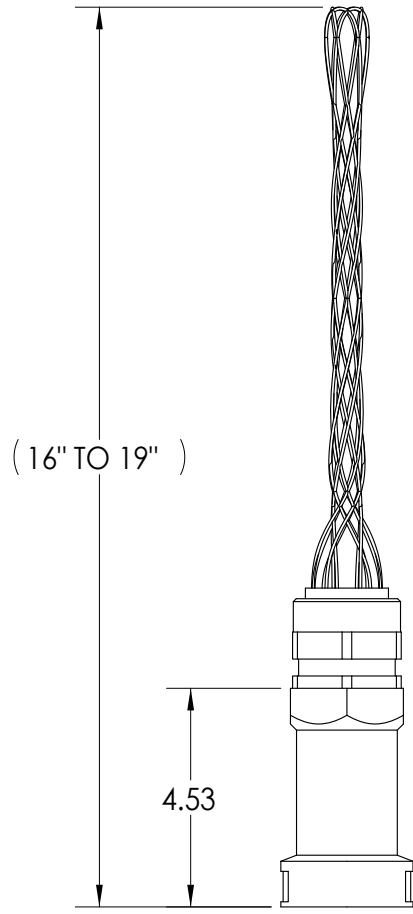

TOLERANCES UNLESS OTHERWISE SPECIFIED		 A COMPANY OF MARECHAL ELECTRIC		DRAWING TITLE:	
MACHINED SURFACES $\sqrt[125]{\text{MAX}}$ GROUND SURFACES $\sqrt[32]{\text{MAX}}$ ANGLE TOLERANCE $\pm 1^\circ$ REMOVE BURRS & SHARP EDGES TO .015 MAX.	ENGLISH 0.X ± 0.05 0.XX ± 0.01 0.XXX ± 0.005			DRAWN: _____ APPROVED: _____ DATE: _____	SCALE: NTS MATERIAL: POLY HANDLE, SS MESH
 DIMENSIONS SHOWN IN OVALS ARE INSPECTION DIMENSIONS.		SHEET: 1 OF 1	PART NUMBER: 44-4A753-x	REVISION: _____	