

This drawing is the property of MELTRIC Corporation, Franklin (Milwaukee) Wisconsin, USA. Any unauthorized copying of this drawing by any means, or disclosure of its contents to any person not authorized by MELTRIC Corporation or its agents to receive it, is strictly prohibited.

ENG/RD/06 REV. 20 ISSUED DATE: 11/15/11

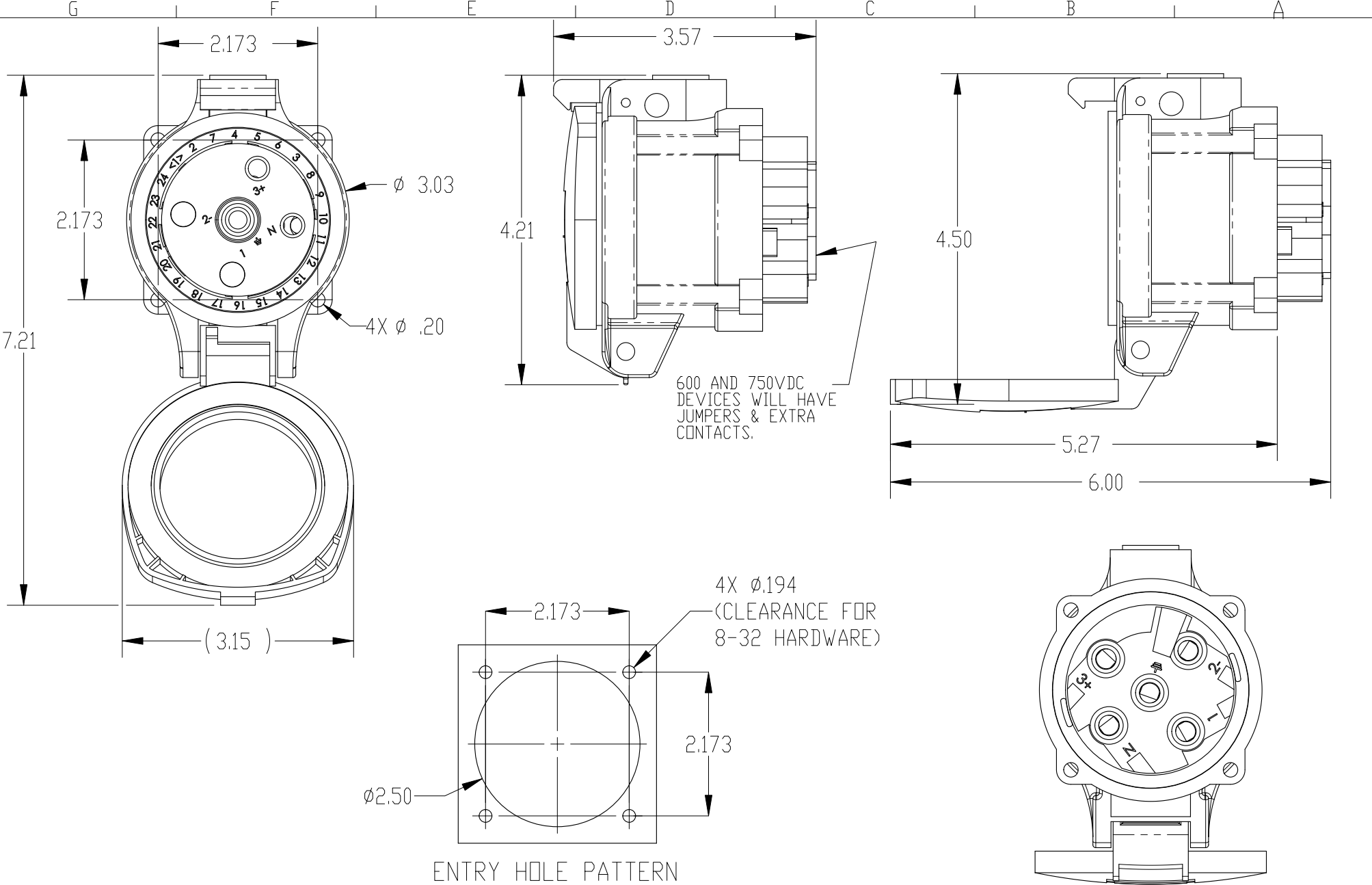

TOLERANCES UNLESS OTHERWISE SPECIFIED		 A COMPANY OF MARÉCHAL ELECTRIC			
MACHINED SURFACES	$\sqrt[125]{\text{MAX}}$			ENGLISH 0.X $\pm 0.05$ 0.XX $\pm 0.01$ 0.XXX $\pm 0.005$	
GROUND SURFACES	$\sqrt[32]{\text{MAX}}$	DRAWN	APPROVED		DRAWING TITLE:
ANGLE TOLERANCE	$\pm 1^\circ$	DATE:	SCALE	MATERIAL:	
REMOVE BURRS & SHARP EDGES TO .015 MAX.		SHEET:	1 OF 1	33-34xxx(-xxx)	REVISION
DIMENSIONS SHOWN IN OVALS ARE INSPECTION DIMENSIONS.					