

This drawing is the property of MELTRIC Corporation, Franklin (Milwaukee), Wisconsin, USA. Any unauthorized copying of this drawing by any means, or disclosure of its contents to any person not authorized by MELTRIC Corporation or its agents to receive it, is strictly prohibited.

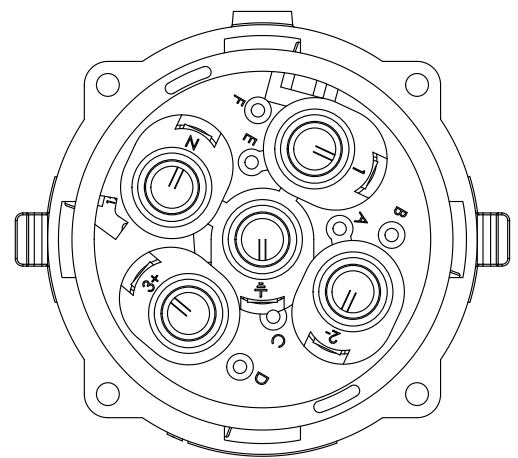

(REAR VIEW)

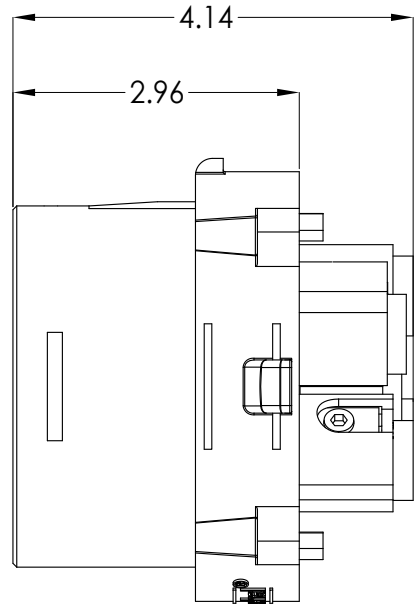
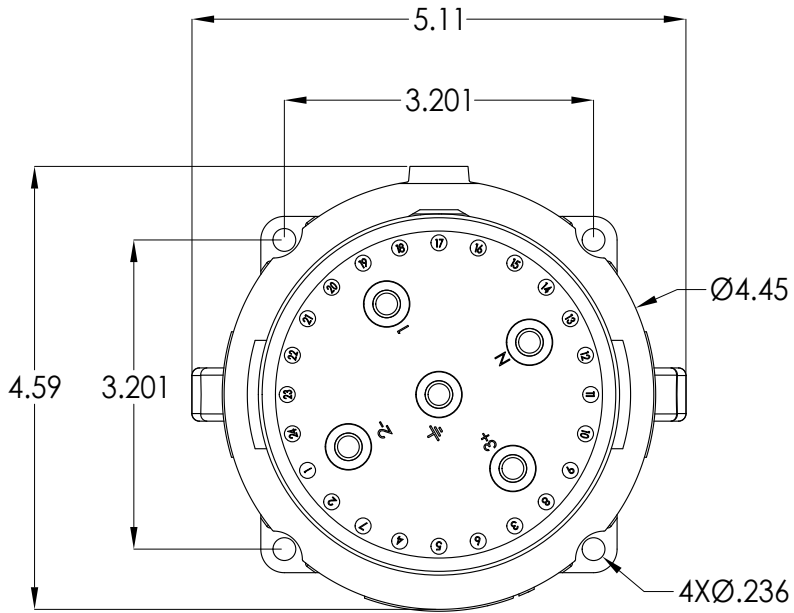
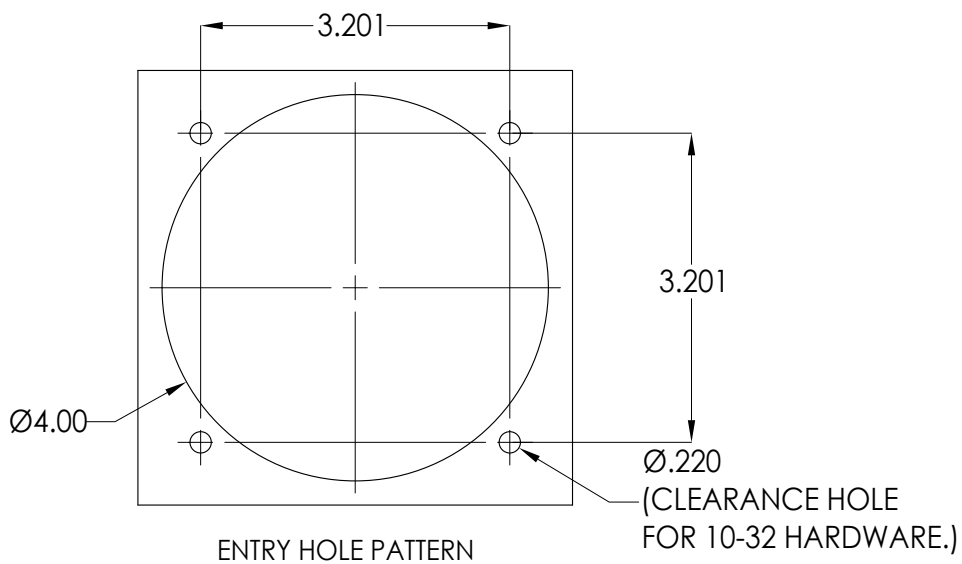

ENTRY HOLE PATTERN

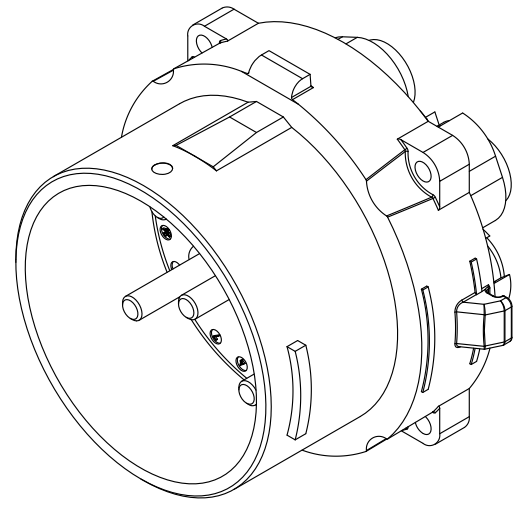

TOLERANCES UNLESS OTHERWISE SPECIFIED		 A COMPANY OF MARÉCHAL ÉLECTRIC		DRAWING TITLE:	
MACHINED SURFACES $\sqrt[125]{\text{MAX}}$	<b>ENGLISH</b> $0.X \pm 0.05$ $0.XX \pm 0.01$ $0.XXX \pm 0.005$			DATE:	SCALE
GROUND SURFACES $\sqrt[32]{\text{MAX}}$			NTS	BLUE POLY CASING	
ANGLE TOLERANCE $\pm 1^\circ$		SHEET:	PART NUMBER		
REMOVE BURRS & SHARP EDGES TO .015 MAX.		1 OF 1	31-98xxx-Kxx		
DIMENSIONS SHOWN IN OVALS ARE INSPECTION DIMENSIONS.			REVISION		