

This drawing is the property of MELTRIC Corporation, Franklin (Milwaukee) Wisconsin, USA. Any unauthorized copying of this drawing by any means, ENGR/D/06 REV: 21 ISSUED DATE: 10/7/16 or disclosure of its contents to any person not authorized by MELTRIC Corporation or its agents to receive it, is strictly prohibited.

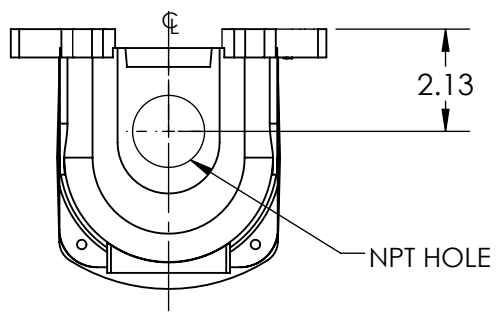

PART NUMBER	NPT SIZE
26-36xxx-12	1/2" NPT
26-36xxx-34	3/4" NPT
26-36xxx-1	1" NPT

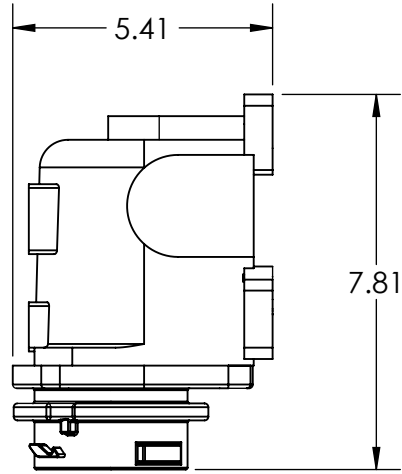
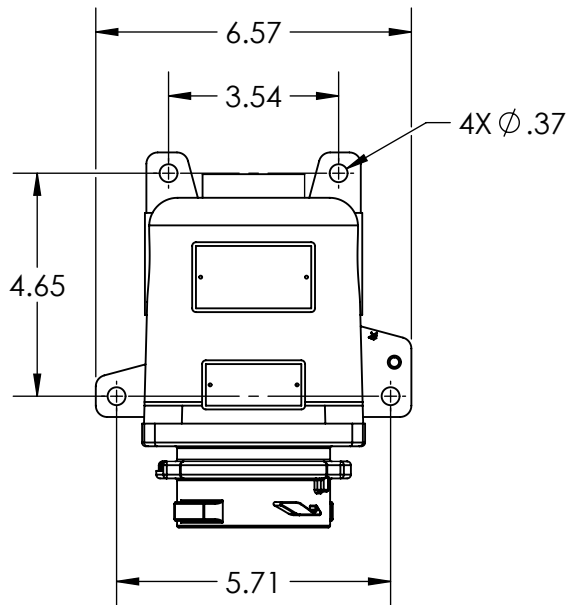
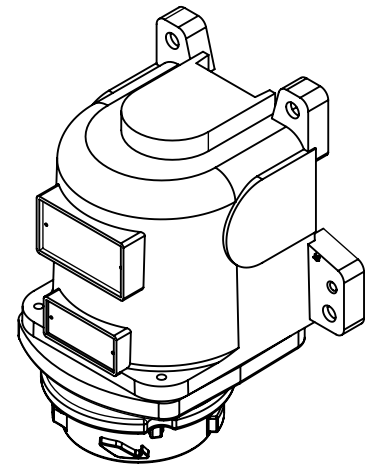

TOLERANCES UNLESS OTHERWISE SPECIFIED		<b>MELTRIC</b> A COMPANY OF MARÉCHAL ÉLECTRIC	
MACHINED SURFACES $\sqrt[125]{\text{MAX}}$ GROUND SURFACES $\sqrt[32]{\text{MAX}}$ ANGLE TOLERANCE $\pm 1^\circ$ REMOVE BURRS & SHARP EDGES TO .015 MAX. DIMENSIONS SHOWN IN OVALS ARE INSPECTION DIMENSIONS.	<b>ENGLISH</b>  0.X $\pm 0.05$ 0.XX $\pm 0.01$ 0.XXX $\pm 0.005$	DRAWN: _____ DATE: _____ SHEET: 1 OF 1	APPROVED: _____ SCALE: NTS MATERIAL: METAL PART NUMBER: 26-36xxx-xx REVISION: _____
		DRAWING TITLE: <b>DX30 INLET ON BOX</b>	