

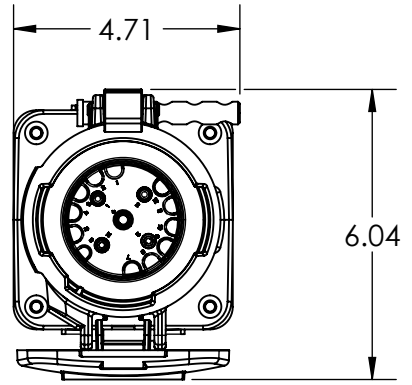

This drawing is the property of MELTRIC Corporation, Franklin (Milwaukee) Wisconsin, USA. Any unauthorized copying of this drawing by any means, ENG/RD/06 REV: 21 ISSUED DATE: 10/7/16 or disclosure of its contents to any person not authorized by MELTRIC Corporation or its agents to receive it, is strictly prohibited.

PART NUMBER	CABLE RANGE
26-33xxx-25M	.35" - .63"
26-33xxx-32M	.47" - .83"

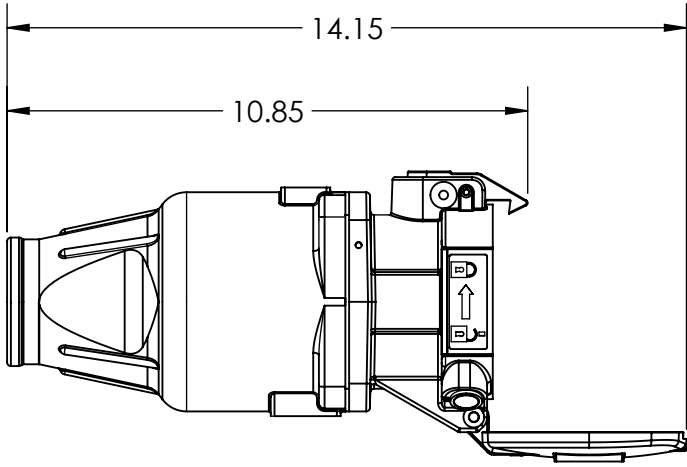
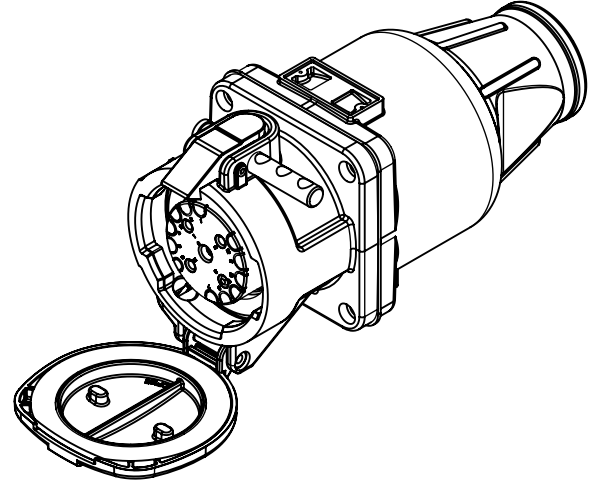

TOLERANCES UNLESS OTHERWISE SPECIFIED		MELTRIC A COMPANY OF MARÉCHAL ÉLECTRIC	
MACHINED SURFACES $\sqrt[125]{\text{MAX}}$	ENGLISH 0.X ±0.05 0.XX ±0.01 0.XXX ±0.005	DRAWN	APPROVED
GROUND SURFACES $\sqrt[32]{\text{MAX}}$		DRAWING TITLE: DX30 CONNECTOR	
ANGLE TOLERANCE ±1° REMOVE BURRS & SHARP EDGES TO .015 MAX.		DATE:	SCALE NTS
 DIMENSIONS SHOWN IN OVALS ARE INSPECTION DIMENSIONS.	SHEET: 1 OF 1	PART NUMBER 26-33xxx-xxx	REVISION