

This drawing is the property of MELTRIC Corporation, Franklin (Milwaukee), Wisconsin, USA. Any unauthorized copying of this drawing by any means, or disclosure of its contents to any person not authorized by MELTRIC Corporation or its agents to receive it, is strictly prohibited.

PART NUMBER	CABLE RANGE
26-23xxx	.31" - .51"
26-23xxx-25M	.35" - .63"
26-23xxx-32M	.47" - .83"

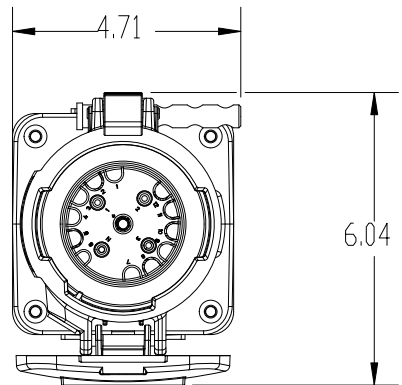
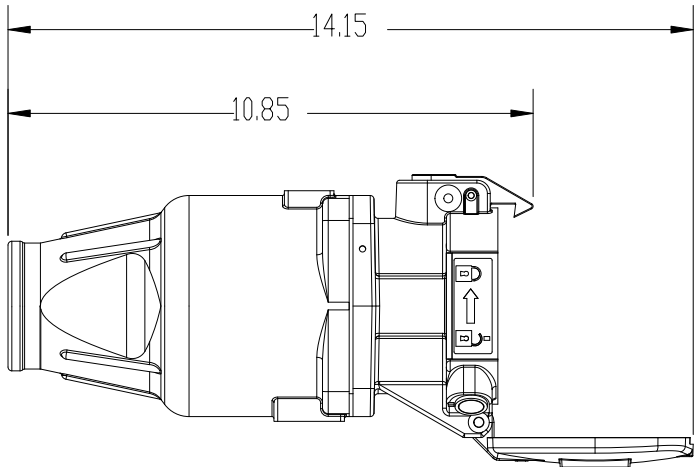
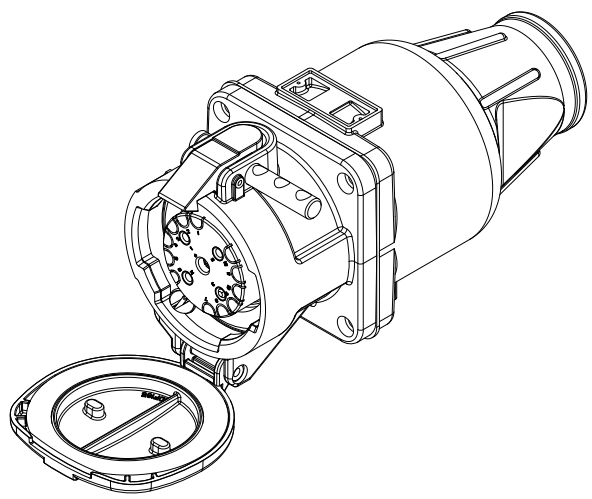

TOLERANCES UNLESS OTHERWISE SPECIFIED		 A COMPANY OF MARECHAL ELECTRIC	
MACHINED SURFACES	$\sqrt[125]{\text{MAX}}$		
GROUND SURFACES	$\sqrt[32]{\text{MAX}}$	SCALE: NTS MATERIAL: METAL	MATERIAL:
ANGLE TOLERANCE	$\pm 1^\circ$	SHEET: 1 OF 1 PART NUMBER: 26-23xxx-xxx	REVISION
REMOVE BURRS & SHARP EDGES TO .015 MAX.			
DIMENSIONS SHOWN IN OVALS ARE INSPECTION DIMENSIONS.			