

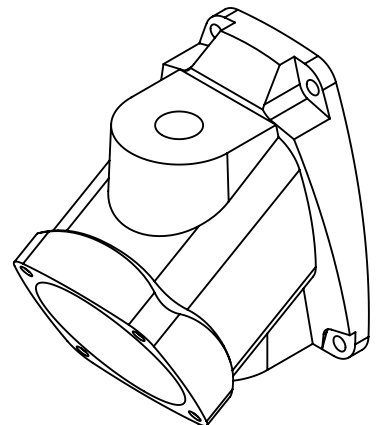

This drawing is the property of MELTRIC Corporation, Franklin (Milwaukee), Wisconsin, USA. Any unauthorized copying of this drawing by any means, ENG/RD/06 REV: 20 ISSUED DATE: 11/15/11 or disclosure of its contents to any person not authorized by MELTRIC Corporation or its agents to receive it, is strictly prohibited.

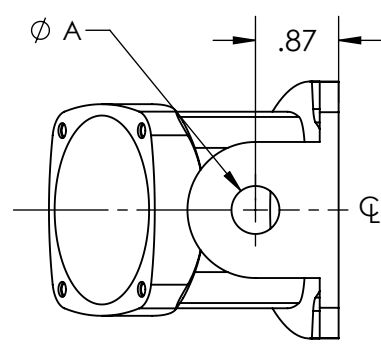
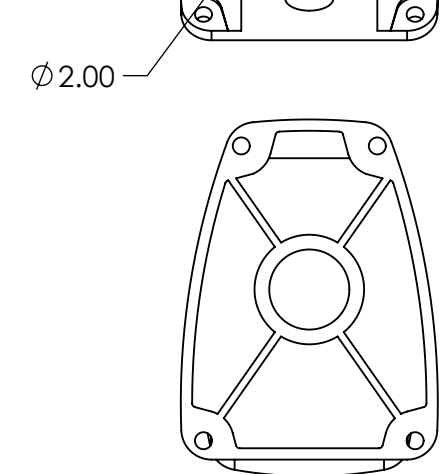
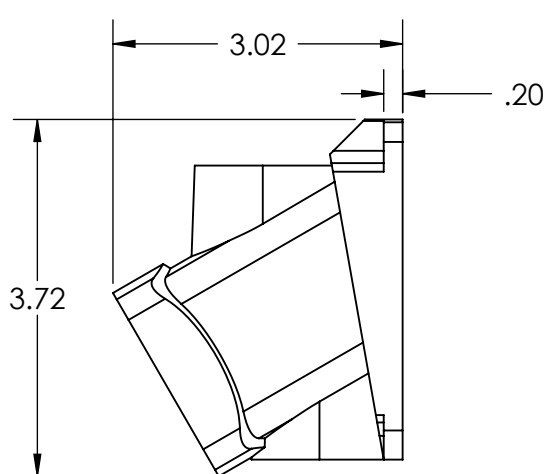
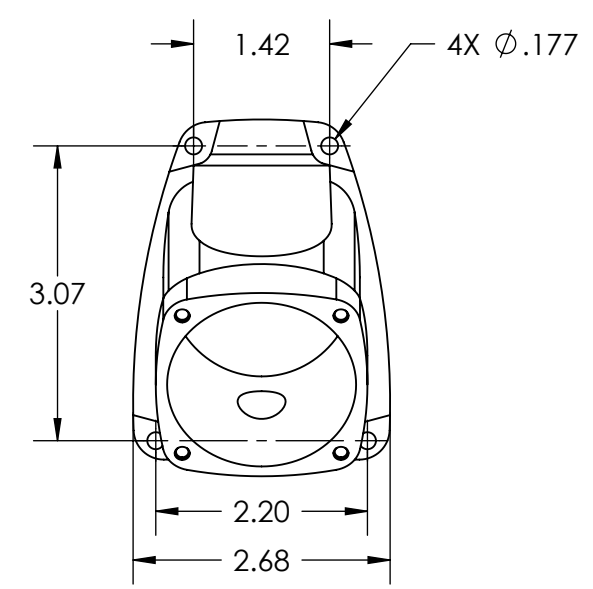
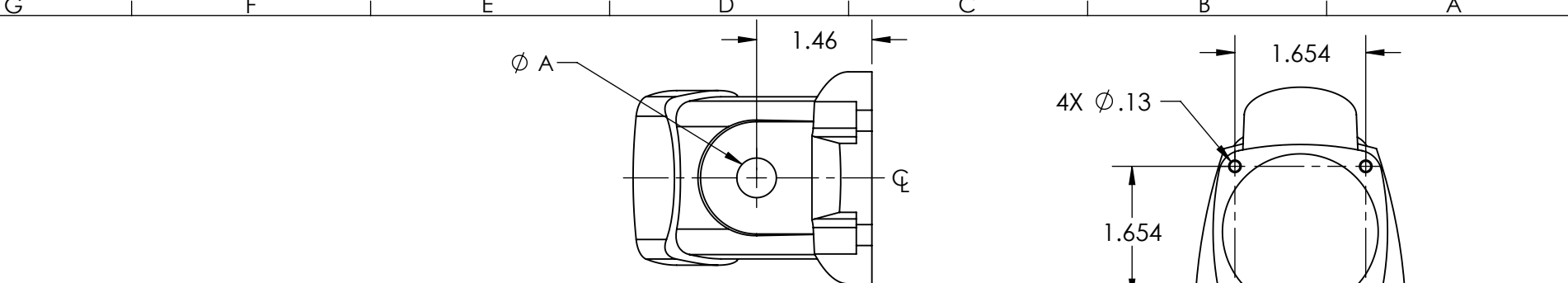

PART NUMBER	NPT "A"
511B3N05	1/2" NPT
511B3N07	3/4" NPT

INTERNAL VOLUME: 6.8 CUBIC INCHES.

TOLERANCES UNLESS OTHERWISE SPECIFIED	
MACHINED SURFACES #error: broken link	ENGLISH 0.X ±0.05 0.XX ±0.01 0.XXX ±0.005
GROUND SURFACES #error: broken link	
ANGLE TOLERANCE ±1°	
REMOVE BURRS & SHARP EDGES TO .015 MAX.	
 DIMENSIONS SHOWN IN OVALS ARE INSPECTION DIMENSIONS.	

		DRAWING TITLE:	
A COMPANY OF MARECHAL ELECTRIC		POLY CONDUIT ENTRY	
DRAWN	APPROVED	SCALE	MATERIAL:
DATE:		NTS	BLUE POLY
SHEET:	PART NUMBER		REVISION
1 OF 1	511B3Nxx		