

This drawing is the property of MELTRIC Corporation, Franklin (Milwaukee) Wisconsin, USA. Any unauthorized copying of this drawing by any means, ENG/RD/06 REV: 21 ISSUED DATE: 10/7/16 or disclosure of its contents to any person not authorized by MELTRIC Corporation or its agents to receive it, is strictly prohibited.

G F E D C B A

PRE-WIRED PILOT CONTACTS:
APPROX. 4" WIRE LENGTH WITH
1/4" FEMALE SPADE TERMINALS

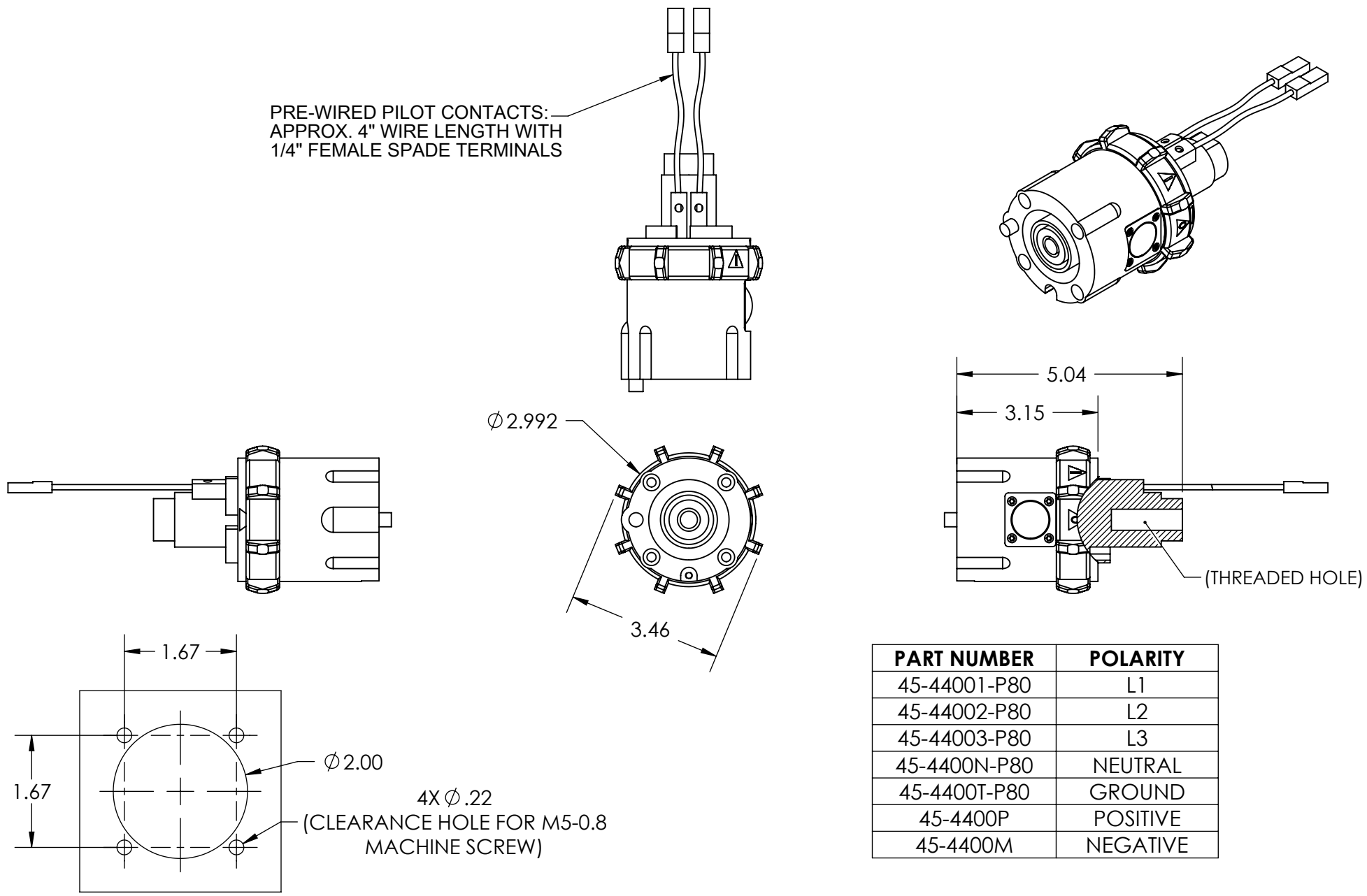

PART NUMBER	POLARITY
45-44001-P80	L1
45-44002-P80	L2
45-44003-P80	L3
45-4400N-P80	NEUTRAL
45-4400T-P80	GROUND
45-4400P	POSITIVE
45-4400M	NEGATIVE

TOLERANCES UNLESS OTHERWISE SPECIFIED

MACHINED SURFACES $\sqrt[125]{\text{MAX}}$	ENGLISH 0.X ± 0.05 0.XX ± 0.01 0.XXX ± 0.005
GROUND SURFACES $\sqrt[32]{\text{MAX}}$	
ANGLE TOLERANCE $\pm 1^\circ$	
REMOVE BURRS & SHARP EDGES TO .015 MAX.	
DIMENSIONS SHOWN IN OVALS ARE INSPECTION DIMENSIONS.	

MELTRIC
A COMPANY OF MARÉCHAL ÉLECTRIC

DRAWN	APPROVED	DRAWING TITLE:	
DATE:		SCALE	MATERIAL:
SHEET:		NTS	BLACK POLY CASING
1 OF 1		PART NUMBER	REVISION
		45-4400x	