

This drawing is the property of MELTRIC Corporation, Franklin (Milwaukee) Wisconsin, USA. Any unauthorized copying of this drawing by any means, ENGR/D/06 REV: 21 ISSUED DATE: 10/7/16 or disclosure of its contents to any person not authorized by MELTRIC Corporation or its agents to receive it, is strictly prohibited.

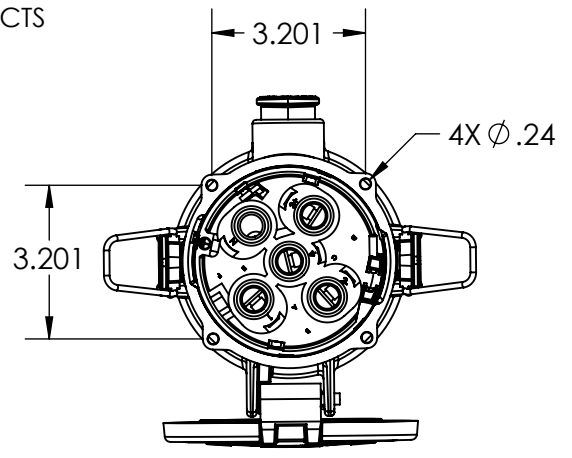
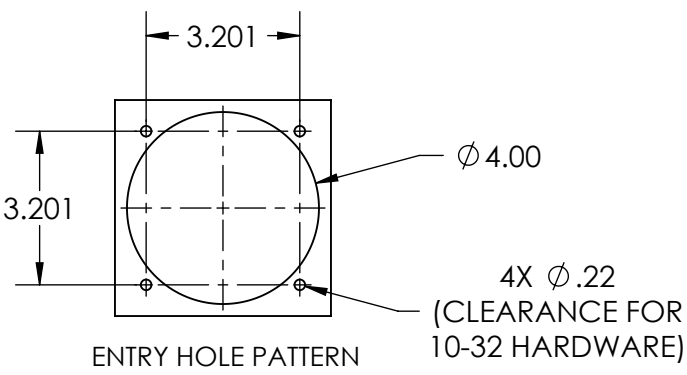
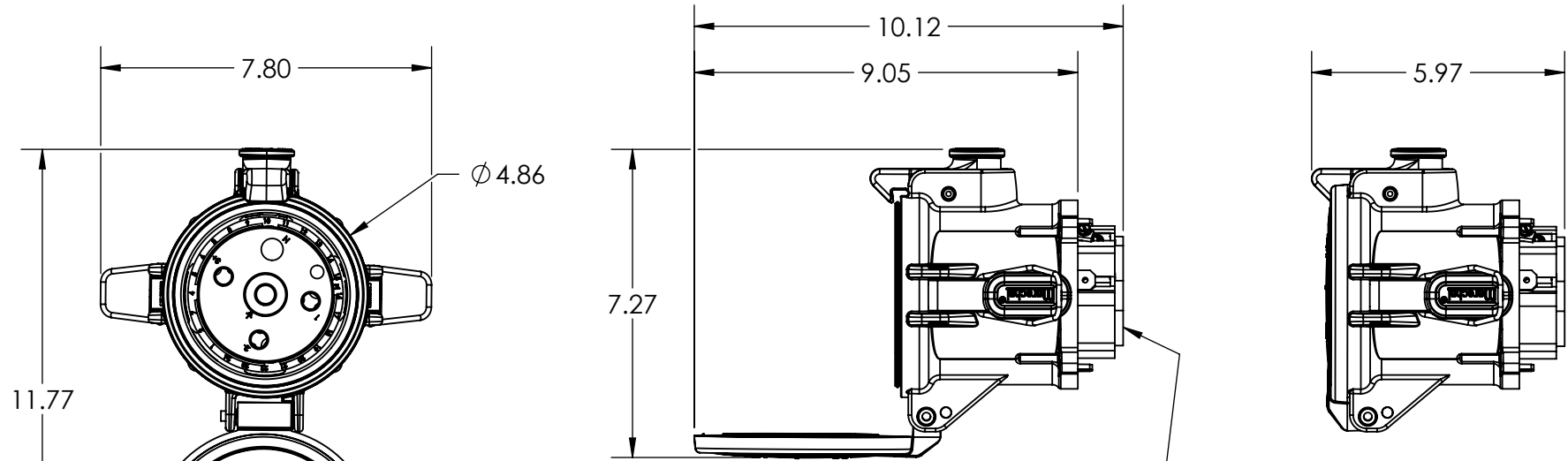

TOLERANCES UNLESS OTHERWISE SPECIFIED	
MACHINED SURFACES $\sqrt[125]{\text{MAX}}$	ENGLISH 0.X ±0.05 0.XX ±0.01 0.XXX ±0.005
GROUND SURFACES $\sqrt[32]{\text{MAX}}$	
ANGLE TOLERANCE ±1°	
REMOVE BURRS & SHARP EDGES TO .015 MAX.	
DIMENSIONS SHOWN IN OVALS ARE INSPECTION DIMENSIONS.	

		DRAWING TITLE:	
A COMPANY OF MARÉCHAL ÉLECTRIC		DSDC9 METAL RECEPT., ALL VOLTAGES/AMPERAGES	
DATE:	SCALE:	MATERIAL:	
	NTS	METAL CASING	
SHEET:	PART NUMBER		REVISION
1 OF 1	37-94x09		